

## Agricultural Coupling Trailer Brake Standard Range - PFT1/PFT3

Application: Agriculture is the specific area for the use of this series. PFT couplings are specifically used to connect the hydraulic brake system.

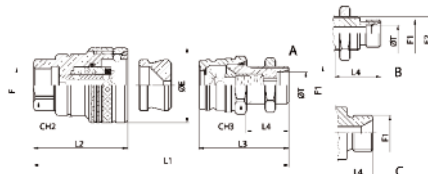

### Carrier

Body Size	ISO Base	CH2	Dimensions				Thread Size	Carrier Half Part Number
			øE	L1	L2	L3		
1/2"	12.5	27	44	55.5			3/8"	PFT1.1310.002
1/2"	12.5	27	44	55.5			1/2"	PFT1.1313.002
1/2"	12.5	27	44	55.5			M 18x1.5	PFT1.1318.102

### Probes

Body Size	ISO Base	CH3	Dimensions				Thread Size	Probe Half Part Number
			L1	L3	L4	øT		
<b>A</b>								
1/2"	12.5	32	90	49	21	12	M 18x1.5	PFT3.1318.503
1/2"	12.5	32	92	51	23	13.5	M 20x1.5	PFT3.1320.503
1/2"	12.5	32	92	51	23	15	M 22x1.5	PFT3.1322.503
<b>B</b>								
1/2"	12.5	32	93.5	52.5	24.5	12	M 16x1.5	PFT3.1336.503
1/2"	12.5	32	93	52	24	13.5	M 18x1.5	PFT3.1338.503
<b>C</b>								
1/2"	12.5	32	89	48	15.5	-	1/2	PFT3.1313.213

### Technical Data

#### Characteristics

PFT couplings are produced according to NFU 16-006/68 corresponding to ISO 5676.

Easy connection and disconnection is possible by retracting the sleeve.

Females of both series are supplied with steel plugs for housing when resting.

#### Material

Zinc plated and yellow bichromated steel with all high stressed components carbonitrided or hardened by induction

Seals: Standard in nitrile NBR. Other seals on request

#### Operating Pressure

150 BAR max.

#### Operating Temperature

with NBR standard seals -25°C to +125°C

#### Special Requests

For assistance, contact our technical office.

## Agricultural Coupling Trailer Brake Standard Range - PFTB

Application: Agriculture is the specific area for the use of this series. PFTB couplings are specifically used to connect the hydraulic brake system. PFTB couplings have a hydraulic locking system to avoid accidental release at minimum 12 BAR pressure.

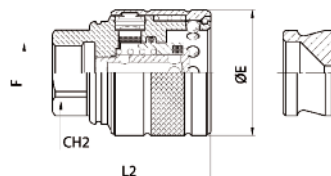

Body Size	ISO Base	CH2	Dimensions		Thread Size	Carrier Half Part Number	Probe Half Part Number
			øE	L2			
1/2"	12.5	27	44	55.5	3/8"	PFTB.1310.002	See PFT
1/2"	12.5	27	44	55.5	1/2"	PFTB.1313.002	-
1/2"	12.5	27	44	5.55	M 18x1.5	PFTB.1318.102	-

### Technical Data

#### Characteristics

PFT couplings are produced according to NFU 16-006/68 corresponding to ISO 5676.

#### Material

Zinc plated and yellow bichromated steel with all high stressed components carbonitrided or hardened by induction

Seals: Standard in nitrile NBR. Other seals on request

#### Operating Pressure

150 BAR max.

#### Burst Pressure

620 BAR (uncoupled)

#### Operating Temperature

with NBR standard seals -25°C to +120°C

#### Special Requests

For assistance, contact our technical office.



## Agricultural Couplings - Tractor Screw Type Flat Face - VVT1/VVT3

Application: Agriculture is the specific area for the use of this series. VVT series are suitable for connection of accessories to agricultural machines.

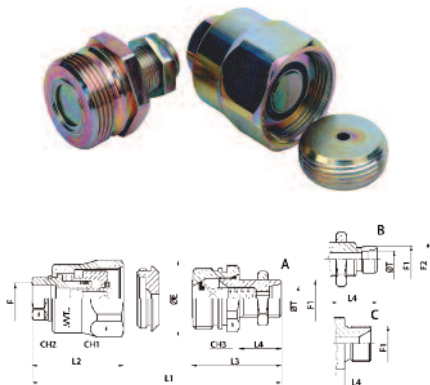

Body Size	ISO Base	CH1	CH2	Dimensions			Thread Size	Carrier Half Part Number
				L1	L2	L3		
1/2"	12.5	41	22		54		3/8"	VVT1.1310.002
1/2"	12.5	41	22		54		M 18x1.5	VVT1.1318.102

Body Size	ISO Base	CH3	L1	L3	L4	øT	Thread Size	Probe Half Part Number
<b>A</b>								
1/2"	12.5	36	88.5	49	21	12	M 18x1.5	VVT3.1318.503
1/2"	12.5	36	90.5	51	23	13.5	M 20x1.5	VVT3.1320.503
1/2"	12.5	36	90.5	51	23	15	M 22x1.5	VVT3.1322.503

### Technical Data

#### Characteristics

These couplings are provided with a screw which allows connection and disconnection under pressure. Females of both series are supplied with steel plugs for housing when resting.

#### Material

Main parts are made of zinc plated and yellow bichromated steel  
Seals: Standard in nitrile NBR. Other seals on request

Back-up Ring: In NBR

#### Operating Pressure

200 BAR

#### Burst Pressure

1380 BAR (coupled)

#### Operating Temperature

with NBR standard seals -25°C to +125°C

#### Special Requests

For assistance, contact our technical office.

## Screw Couplings - For Tippers - VCR



### VCR Series

Body Size	Thread Size	Carrier Half Part Number	Probe Half Part Number
16	3/4 BSP	VCR-C-16F	VCR-C-16M
20	1 BSP	VCR-C-20F	VCR-C-20M
Dust Caps and Plugs		Dust Plug	Dust Caps
16	3/4 BSP	V-DP-16	V-DC-16
20	1 BSP	V-DP-20	V-DC-20
Anchor Bracket			
16	3/4 BSP	VCR-A BRACKET-16	
20	1 BSP	VCR-A BRACKET-20	

### Technical Data

#### Characteristics

VCR series specifically designed for application on lorry trailers

#### Material

Carbon Steel, Zinc plate passivated

#### Operating Pressure

3/4" 250 BAR

1" 230 BAR

#### Operating Temperature

-25°C to +125°C

#### Special Requests

For assistance, contact our technical office.